

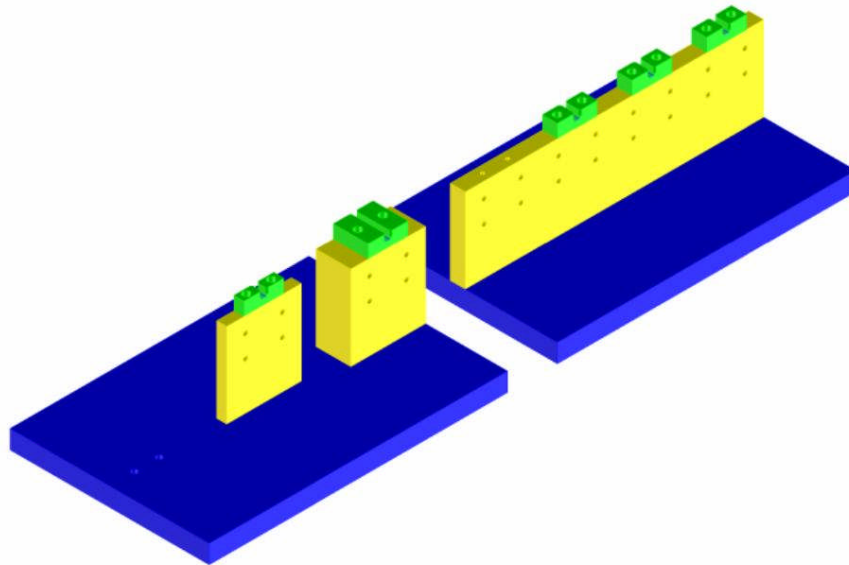

Product Note: B6138190

Attaching Coax-to-Microstrip Transitions to ICM Calibration Kits A0137699, A0137987, and A0138119



Serving the Microwave Industry since 1985

Solution Partner with Maury Microwave



6849 W Frye Rd, Chandler AZ, 85226
Tel: (480) 940-0740 Fax: (480) 961-4754
E-mail: sales@icmicrowave.com Website: www.icmicrowave.com

Coax-to-Microstrip Transition Assembly Mounting

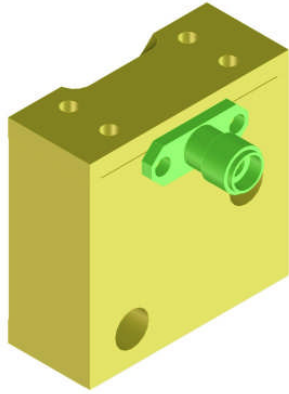

This picture shows the Transition Assembly, A0138085, with a K connector. The transition has two mounting holes.

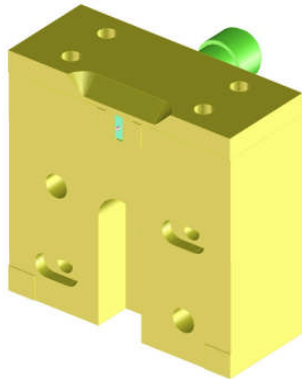

The inside of the Transition Assembly has three raised areas where the ground contact is made. The RF pin extends by 25 mils from the ground area. The RF pin is spring-loaded from the bottom side.

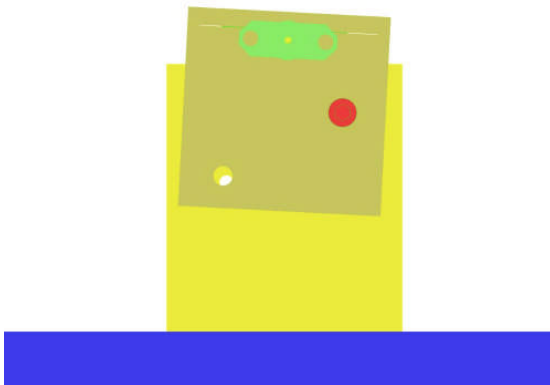

When attaching the Transition to a calibration standard, insert the upper screw first and tilt the transition by approximately three degrees. Insert the screw all the way, but do not tighten it. This maneuver protects the RF pin while mounting the Transition.

See our website at www.icmicrowave.com for more details

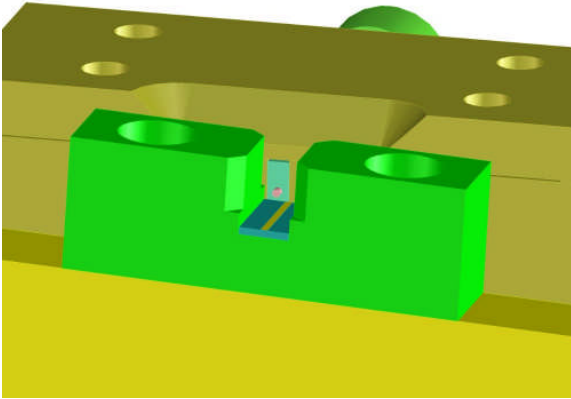

This picture shows the position of the RF pin when the Transition is tilted by three degrees. When attaching the first screw, make certain that the RF pin is in this position.

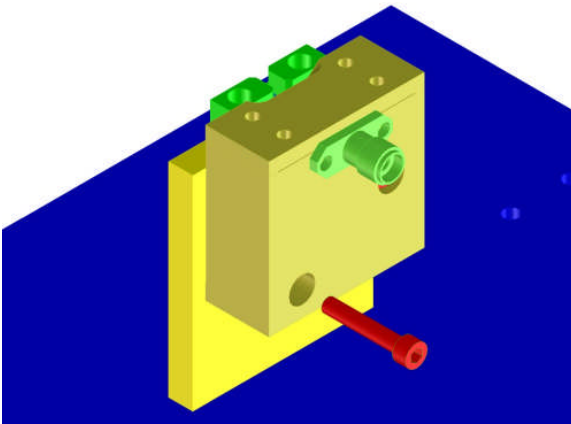

Carefully rotate the Transition back to the horizontal position, and insert the second screw. The weight of the Transition will automatically apply sufficient force for the RF pin to make contact. Tighten screw number one and number two securely.

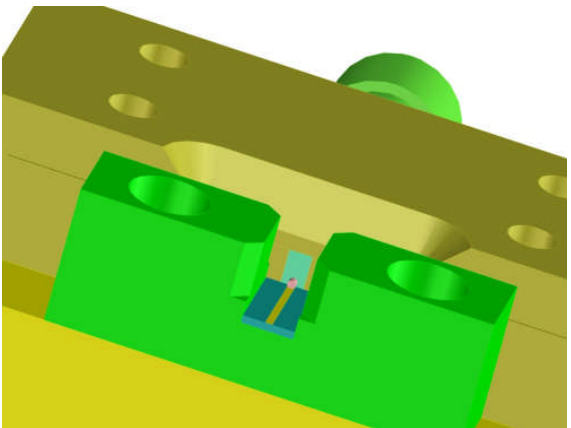

After the Transition is rotated back by three degrees, the RF pin should make contact in the middle of the microstrip.

See our website at www.icmicrowave.com for more details

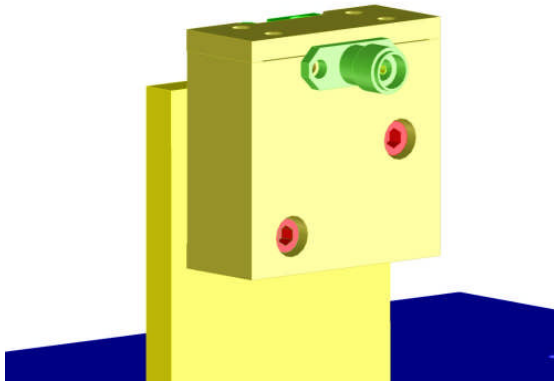

Examine the screws, and make certain that they are securely fastened. This is important in order to have good ground contact.

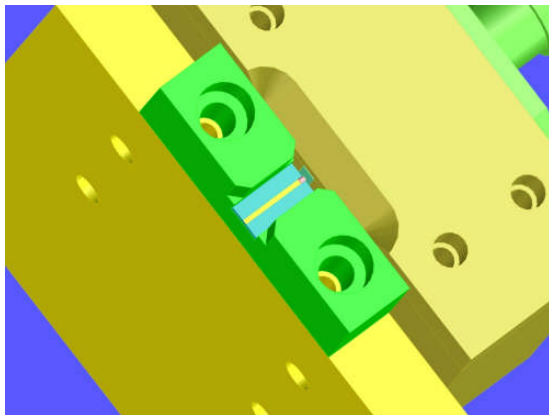

Re-check the RF pin, and make certain that it is properly seated on the microstrip. It should be exactly in the middle of the microstrip line.

Spare parts for Transition Assembly A0138085:

RF-Pin:	72137490
Sleeve Dielectric:	73136248A

Inter-Continental Microwave

6849 W Frye Rd, Chandler AZ, 85225
Tel: (480) 940-0740 Fax: (480) 961-4754
E-mail: sales@icmicrowave.com Website: www.icmicrowave.com